

INSTALLATION & SERVICE MANUAL

Countertop Reverse Osmosis Systems

Series CT

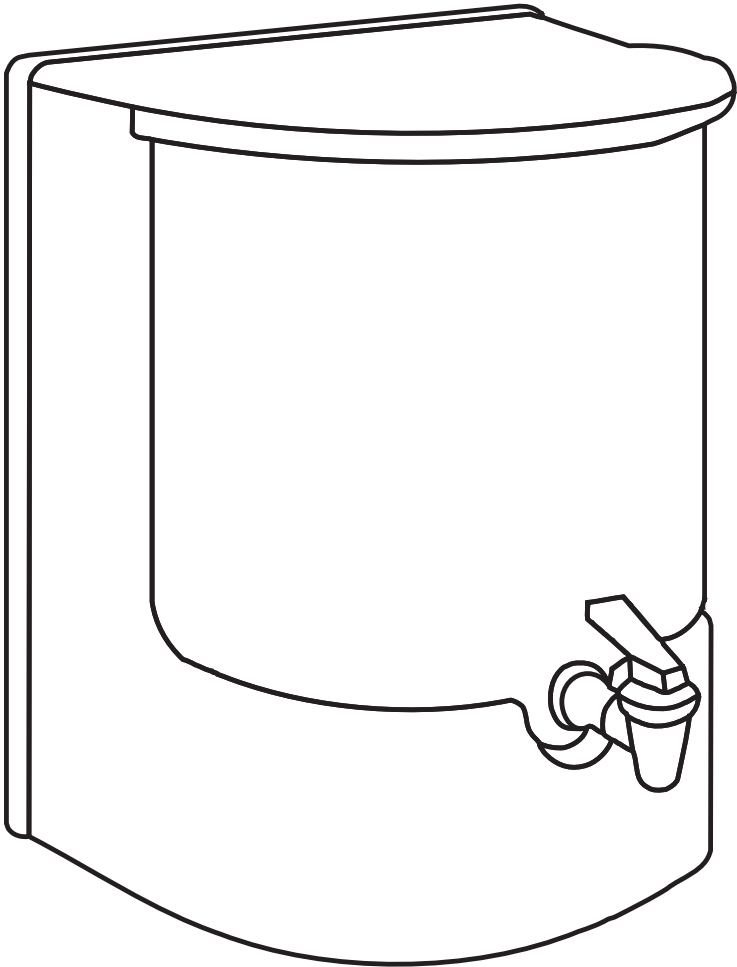

Thank you for choosing a Series CT counter top reverse osmosis drinking water system. With proper care your water filtration system will produce high quality drinking water for many years.

Read carefully and follow the instructions in this manual before installation. Pay particular attention to all warnings, cautions and notes. Failure to do so could result in personal injury or damage to the equipment or other property. System and installations need to comply with state and local laws and regulations.

There are many benefits from using reverse osmosis water. Not only will you enjoy high quality drinking water, but also will find the water unsurpassed for:

- Cooking • Juices • Coffee and Tea • Ice Cubes • Low Sodium Diets • Baby Formulas • Weight Loss Diets • Steam Irons • Car Batteries • Household Plants • Windshield Washers • Humidifiers • Pets • Aquariums

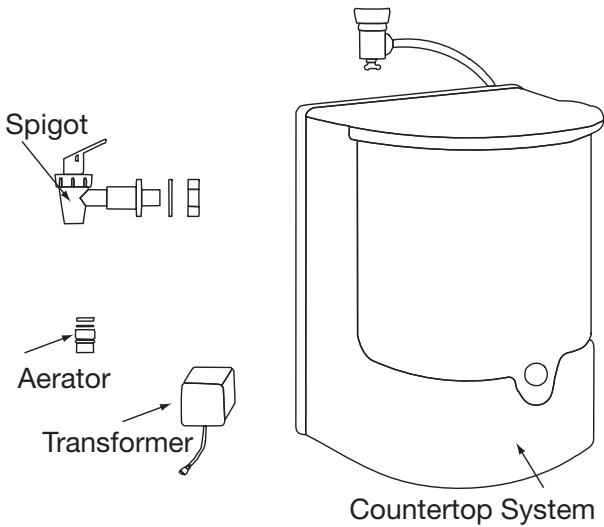

<Fig.1>

Remove the unit carefully, check for any damage.

CHECKLIST: See <fig. 1>

1. Spigot
2. Transformer (N/A with CT-445NF)
3. Countertop RO System
4. Special aerator (CT-322) with 2 adapters (13/16, 15/16)
5. Series CT Manual

SPIGOT INSTALLATION

Wipe the inside of the water reservoir and rinse with clean water.

Install the spigot as shown in <Fig.2>. It is important that the rubber washer be installed on the outside of the reservoir. Hand tighten by turning the spigot. Do not over tighten.

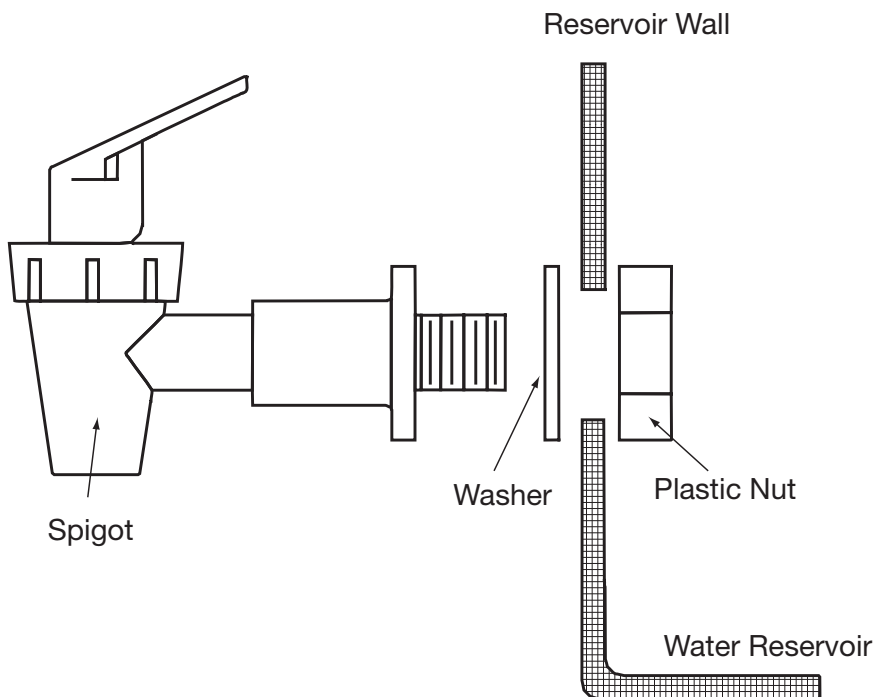

<Fig.2>

FAUCET AERATOR INSTALLATION

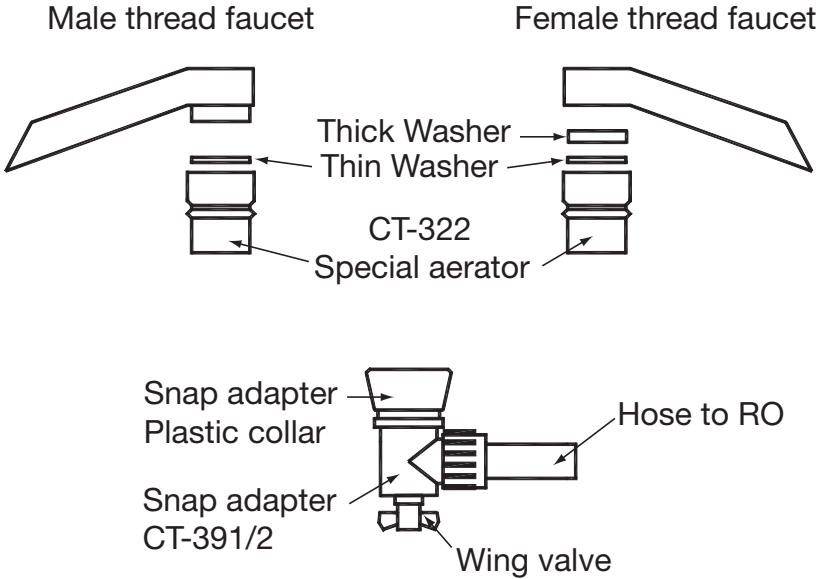

<Fig.3>

Remove the existing aerator from the faucet and attach the new special aerator (CT-322) included with the RO unit. Consult <fig.3>. The special aerator included with the RO unit will fit most standard faucets. However, if the aerator does not fit your faucet, consult your dealer. Most hardware or plumbing stores carry a complete line of faucet adapter fittings. When tightening the fitting use a pair of pliers and tighten carefully (wrap tape around the jaws to prevent marring the fittings).

To attach the faucet snap adapter to the special aerator, pull down on the snap adapter plastic collar and push onto the special aerator until it seats. Release the plastic collar. The plastic collar will snap into place.

It is important that the hose lay flat on the counter with no sharp bends or kinks. This will allow the overflow failure to function properly.

START UP

Open the plastic wing valve (see <fig.3>) two full turns (counterclockwise). And slowly turn on the cold water.

NOTE: Do not allow hot water to enter the unit. This will permanently damage the membrane.

Water will fill the unit and also flow from the bottom outlet of the wing valve.

Do not completely shut off the reject water. This will damage the membrane.

The reservoir will slowly fill. The rate at which the reservoir fills will vary with water pressure and water temperature. Typical water production will be $\frac{3}{4}$ to 1 gallon per hour. Discard the first two full reservoirs before using. This will insure that any loose filter material is flushed from the system prior to use.

NOTE:

- 1. Do not connect to hot water.**
- 2. Do not allow to freeze.**
- 3. Do not restrict the reject flow (wing valve) beyond 4-6 oz per 30 seconds (110-200 ml/30 seconds)**

A: Faucet

B: Plastic wing valve

C: Electrical outlet

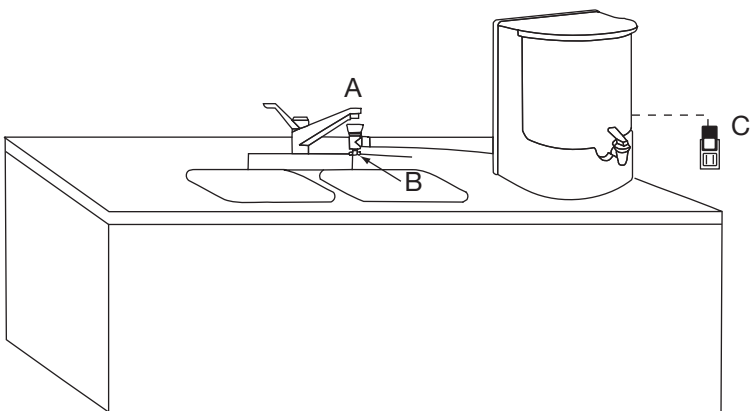

<Fig.4> Typical layout of CT Series

HELPFUL HINTS

Proper reject flow . . .

It is important that the reject water flow from the wing valve at all times. This flow of reject water removes the unwanted contaminants from the membrane. Restricting this flow allows the impurities to build up on the membrane and the membrane will be damaged. Make sure that this flow yields 1/2 glass or cup in 30 seconds (110-200 ml/30 seconds). This will protect the membrane. To clean the reservoir, use baking soda and a soft cloth. To sanitize the water reservoir let stand for 1 hour. Rinse thoroughly before using the unit.

OVERFLOW

It is important that the hose lay flat on the counter for the overflow system to work properly.

Model	CT-445	CT-445P	CT-545U	CT-545UP
Pressure (Min.-Max.)	40-75 PSI	10-75 PSI	40-75 PSI	10-75 PSI
pH	3-11	3-11	3-11	3-11
Temperature	40-110°F	40-110°F	40-110°F	40-110°F
Product Water	35 GPD	35 GPD	35 GPD	35 GPD
Recovery Rate	25-30%	25-30%	25-30%	25-30%
Rejection Rate	80-90%	92-96%	80-90%	92-96%
System Dimension (LxWxH in.)	11.5x11x14	11.5x11x14	11.5x11x14	11.5x11x14
Storage Capacity	1.25 Gallon	1.25 Gallon	1.25 Gallon	1.25 Gallon
Shipping Weight (lb)	15	20	17	22

INSTALLATION GUIDE TANK LEVEL CONTROL (TLC) LAYOUT

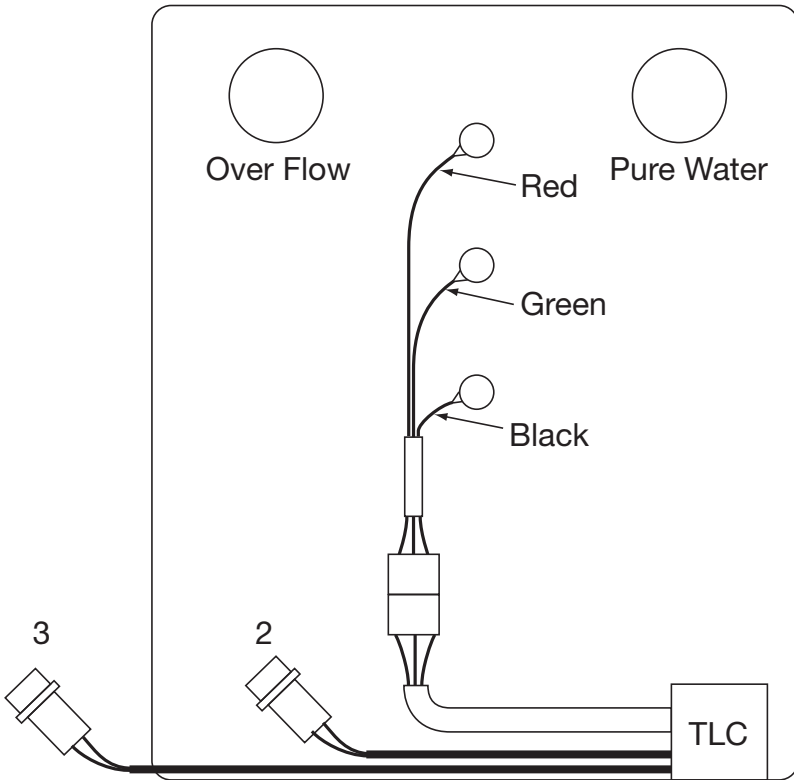

<Fig.5>

1. 3 pin connection for sensor wire
2. 2 pin connection for pump
3. 2 pin connection for transformer

CT-445 FILTRATION PROCESS

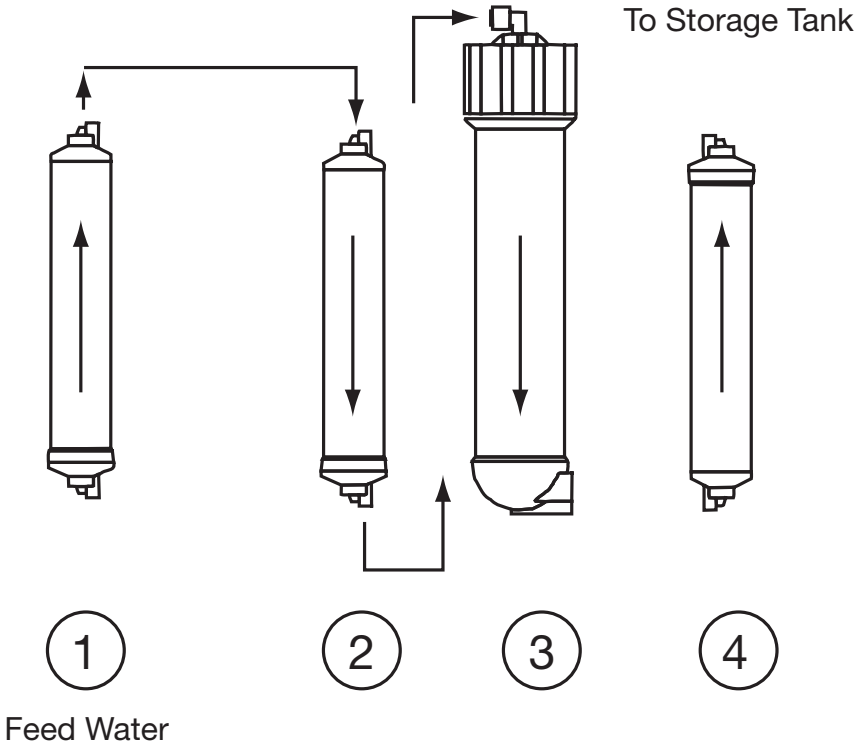

<Fig.7>

No.	Part No.	Descriptions	Service life
1	FI-SED010S	Inline sediment filter	6-12 months
2	FI-CBA010S	Inline GAC filter	6-12 months
3	MM-TFF45/75	TFC membrane, 35GPD (CT-445)	2-3 years
4	FI-CBA010S	Inline GAC filter	12-18 months

CT-445P FILTRATION PROCESS

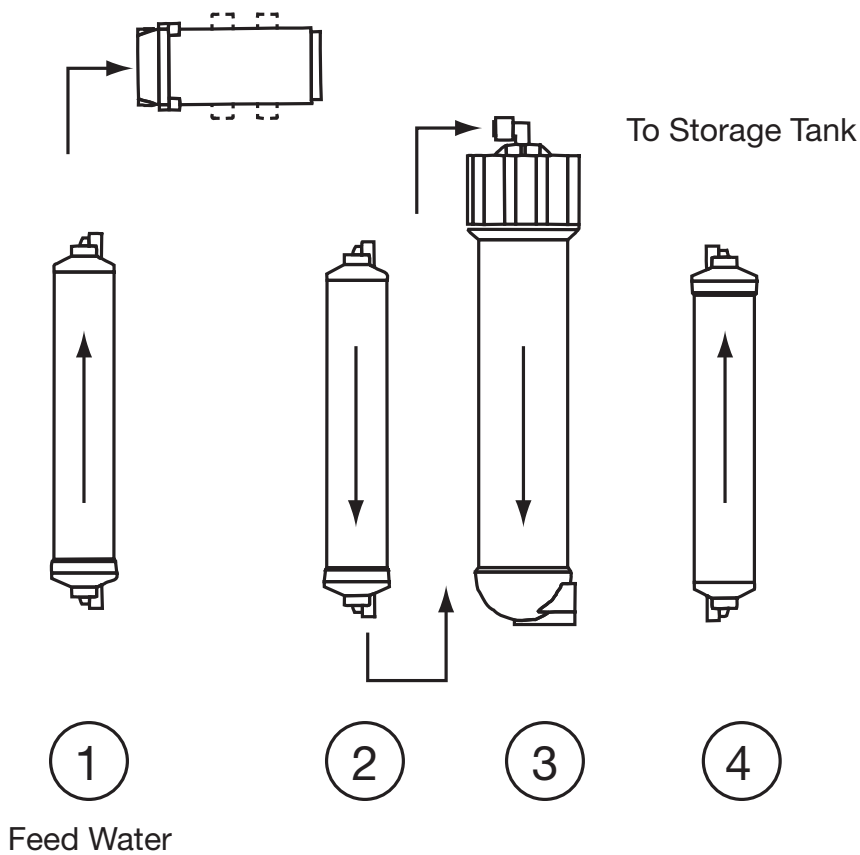

<Fig.8>

No.	Part No.	Descriptions	Service life
1	FI-SED010S	Inline sediment filter	6-12 months
2	FI-CBA010S	Inline pre carbon filter	6-12 months
3	MM-TFF45/75	TFC membrane, 35GPD (CT-445P)	2-3 years
4	FI-CBA010S	Inline post carbon filter	12-18 months

TROUBLESHOOTING

PROBLEM	CAUSE	SOLUTIONS
Milky colored water	<ul style="list-style-type: none"> ✓ Air in system 	<ul style="list-style-type: none"> <input type="checkbox"/> Air in the system is a normal occurrence with initial start up of the RO system. The milky look will disappear during normal use within 1 to 2 weeks.
Slow production	<ul style="list-style-type: none"> ✓ Low water pressure ✓ Crimps in tubing ✓ Clogged prefilters ✓ Fouled membrane 	<ul style="list-style-type: none"> <input type="checkbox"/> Add a booster pump <input type="checkbox"/> Make sure tubing is straight <input type="checkbox"/> Replace prefilter <input type="checkbox"/> Replace membrane
Water taste or smell offensive	<ul style="list-style-type: none"> ✓ Post carbon depleted ✓ Fouled membrane 	<ul style="list-style-type: none"> <input type="checkbox"/> Replace post carbon <input type="checkbox"/> Replace membrane
No drain water	<ul style="list-style-type: none"> ✓ Clogged flow restrictor 	<ul style="list-style-type: none"> <input type="checkbox"/> Replace flow restrictor
Leaks	<ul style="list-style-type: none"> ✓ Fittings are not tightened ✓ Twisted O-ring 	<ul style="list-style-type: none"> <input type="checkbox"/> Tighten fittings as necessary <input type="checkbox"/> Replace O-ring.

Limited One Year Warranty

1. What your warranty covers:

Series CT countertop reverse osmosis systems are warranted to the original owner to be free of defects in material and workmanship from the date of manufacture for one-year excluding the replaceable filters.

2. Conditions of warranty:

- a) System must be maintained and serviced with approved replacement parts and filters. The performance of your drinking water system is directly related to the quality of the water being treated and the particular application for which it is used. Therefore, the manufacturer's liability is limited to the cost of repair or replacement (at our option) of any defective part and does not include incidental or consequential damage of any kind. This warranty gives you specific legal rights and you may also have other rights, which vary, from state to state
- b) System must be installed and operated in accordance with the manufacturer's recommended procedures and guidelines.
- c) Warranty is void if product failure or damage results from freezing, neglect, misapplication, fouling with sediment or scale or failure to operate the system in accordance with the instructions contained in the owner's manual.
- d) The following operating conditions must also be followed for this warranty to be valid.
 - The hardness of the water can not exceed 7 grains per gallon or 120 ppm.
 - Iron should be less than 0.3 ppm
 - The pH of the water must not be lower than 3 or higher than 11.
 - Incoming Total Dissolved Solids can not exceed 1000 ppm.

3. Limitations and Exclusions:

The manufacturer will not be responsible for any implied warranties, including those of merchant ability and fitness for a particular purpose. The manufacturer will not be responsible for any incidental or consequential damages, including travel expense, and telephone charges. Loss of revenue, loss of time, inconvenience, loss of the equipment or damage caused by the equipment and its failure to function properly are excluded. This warranty sets forth all of the manufacturer's responsibilities regarding this equipment.

